

CD150M Dri-Prime® Pumps

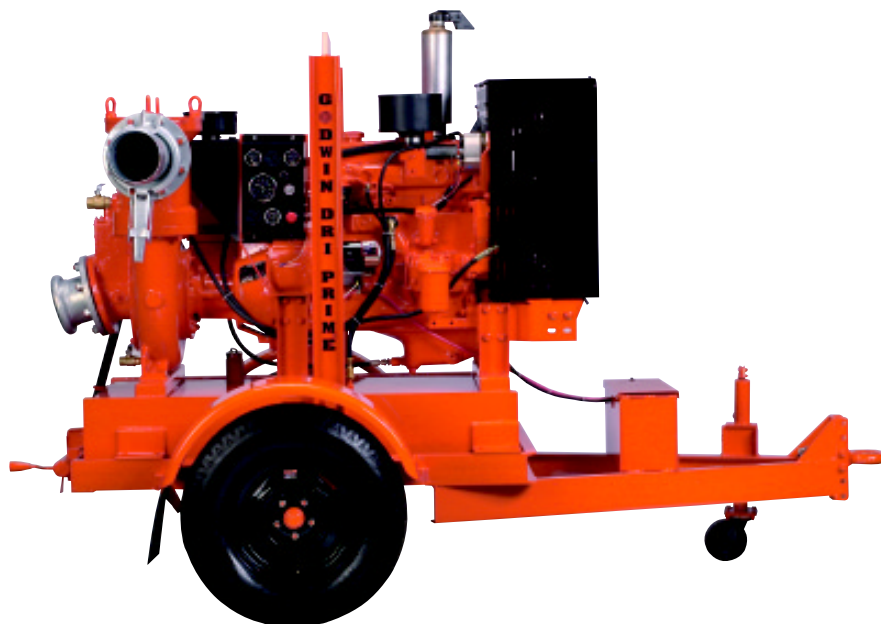

The Godwin Dri-Prime 6" CD150M automatic priming centrifugal pump is clearly the backbone of the temporary portable pumping industry. With solids-handling to 3" in diameter, maximum flows of 1700 gallons per minute and 160 feet of total dynamic head, and indefinite dry-running capabilities, the CD150M can be found in a wide variety of applications from straight dewatering to sewage bypassing. Mounted on a highway trailer, the CD150M is the most maneuverable and versatile portable pumping system available, making it a favorite of contractors, municipalities, industry and environmental companies across the country.

Features

- Close coupled centrifugal pump with vacuum priming compressor mounted to a diesel engine. Also available in electric drive or as bare shaft pumpend.
- All cast iron construction with cast chromium steel impeller.
- Extensive application flexibility — will handle raw sewage, slurries and liquids with solids up to 3" in diameter.
- Continuously operated "Godwin" patented air ejector priming device requiring no periodic adjustment or control.
- Dry running, oil bath, mechanical seal with abrasion resistant solid silicon carbide interfaces.
- Solids handling ball type Non Return Valve with renewable flexible rubber seat and quick release access feature.
- Compact unit mounted on skid base or two wheeled highway trailer both incorporating integral overnight running fuel tank.
- Simple maintenance — normally confined to checking engine and seal cavity oil levels.
- Standard John Deere 4045D or Caterpillar 3054NA engine. Also available with a variety of other engines including Hatz, Perkins and Deutz.
- Super-quiet critical silence pack version available for use in residential communities.

CD150M Performance Curve

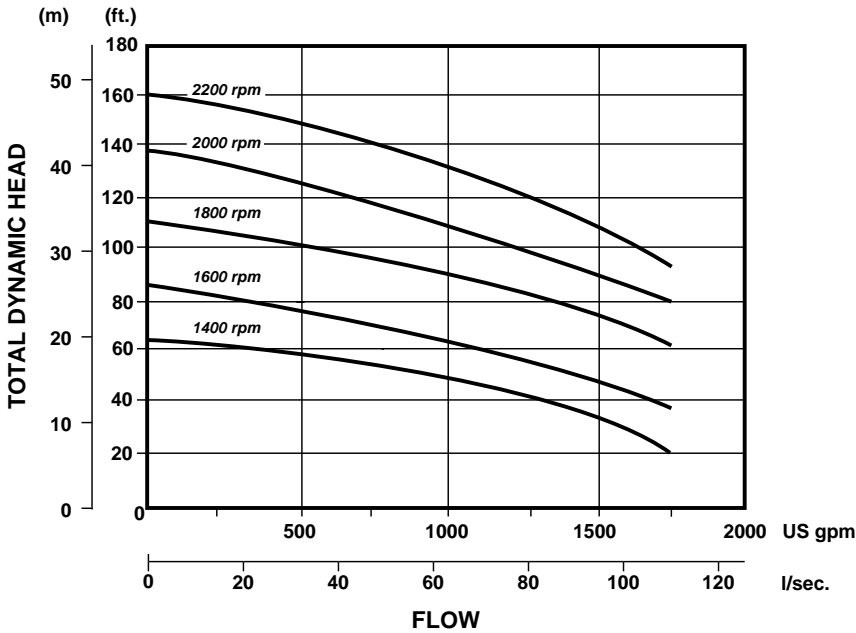

Performance Table

Diesel Set: John Deere 4045D, 71 hp @ 2200 rpm
 Caterpillar 3054NA, 74 hp @ 2200 rpm
 Impeller Diameter — 10.8"

Total Suction Head — Feet	Total Delivery Head — Feet				
	10	20	30	40	50
10	1960	1900	1850	1800	1680
15	1850	1810	1700	1520	1400
20	1670	1590	1500	1380	1240
25	1500	1400	1340	1240	1100

Performance data listed in table and curves are based on water tests at sea level and 68° F (20° C). Larger diameter pipes may be required for maximum flows.

Dimensions

CD150M — shown with John Deere 4045D, GP60 Highway Trailer
 Weight: 3200 lbs.

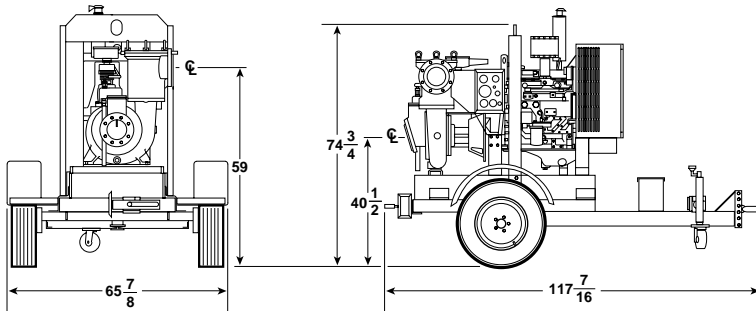

All dimensions listed in inches.

Specifications

- Maximum Operating Speed:**
2200 rpm
- Maximum Operating Temperature:**
+212° F (100° C)
- Maximum Working Pressure:**
58.5 psi
- Maximum Suction Pressure:**
40.0 psi
- Maximum Casing Test Pressure:**
88.0 psi
- Fuel Tank Capacity:**
60 to 100 gallons (60 gallon standard)
- Fuel Consumption (full load):**
John Deere 4045D: 3.82 gph @ 2200 rpm
Caterpillar 3054NA: 4.3 gph @ 2200 rpm
- Pipe Connections:**
6" ASA 150#
- Solids Handling:**
3" dia., standard impeller

Materials

- Pump Casing, Suction Cover, Separation Tank and Wearplates:**
Close grained cast iron
- Impeller:**
Cast chromium steel hardened to minimum Brinell 341 HB
- Shaft:**
1-1/2% nickel/chromium steel
- Non Return Valve Body, Ejector Housing:**
Close-grained cast iron
- Non Return Valve – Ball and Seat:**
High nitrile rubber
- Mechanical Seal Faces:**
Solid silicon carbide



One Floodgate Road, Bridgeport, NJ 08014
 Tel: (856) 467-3636 • Fax: (856) 467-4841
 E-mail: sales@godwinpumps.com
 www.godwinpumps.com

BRANCH LOCATIONS:
 Norwich, CT • Buffalo, NY • Chicago, IL
 Washington, DC • Richmond, VA • Virginia Beach, VA • Charleston, WV • N. Charleston, SC
 Atlanta, GA • Houston, TX • Raleigh, NC

Dri-Prime® is a registered trademark of Godwin Pumps of America, Inc. Specifications and illustrations are subject to revision without notice. © Copyright 2001. Godwin Pumps of America, Inc. All rights reserved.